



Structures - Deployment

11 March 2023

Medusa Deployment Mechanism Needs:

- Deploy all four parachutes successfully
- Limit cost/weight/complexity of system
- Be viable at high altitudes (low pressure, low temperature)
- Preventing early deployment
- Preventing parachute loss



Concept 1: Black Powder Piston

- A small piston attaches to a diaphragm and cup that holds soft goods. E-matches ignite sealed black powder charges which extend the piston and break the shear-pins.
- Two pistons: One inside the AV Tower points upward toward main parachute, and second is under AV tower pointing downward.

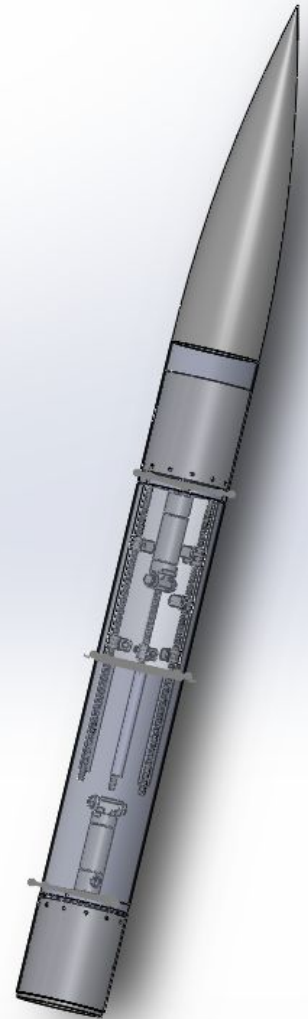

Black Powder Piston: Mass and Dimension

- Piston: 1 lb
- Aluminum diaphragms: $0.3 \text{ lb} * 2 = 0.6 \text{ lb}$
- Brass fittings: 0.1 lb
- Fiberglass cup: 0.3 lb
- Anti-rotation rod: 0.05 lb
- Rope guide: 0.05 lb

Total: ~2.05 lb per mechanism



Black Powder Piston: Cost Estimate

- Piston: \$35.33
- Aluminum diaphragms: \$22.89
- Brass fittings: \$1.23 each
- Fiberglass cup: \$11.44
- Anti-rotation rod: \$6.93
- Rope guide: \$10

Total: \$87.82 per mechanism



Black Powder Piston: Pros and Cons

Pros

- Familiar system
- Relatively cheap

Cons

- More space required
- Necessity for more vacuum testing
- Heavier system
- Difficulties in high altitude deployment



Concept 2: CO₂ Cartridge

- Cartridge releases CO₂ into sealed parachute chamber, increasing the pressure within to break the shear pins and deploy the parachute
 - Chamber sealed by fiberglass bulkheads on top and bottom
- CO₂ is released by a mechanism that punctures the cartridge such as premade CO₂ ejection systems available for purchase online (Eagle)



CO₂ Cartridge: Mass and Dimension

- RAPTOR & EAGLE: 4 oz without CO2
 - 16g canister: 0.7 oz

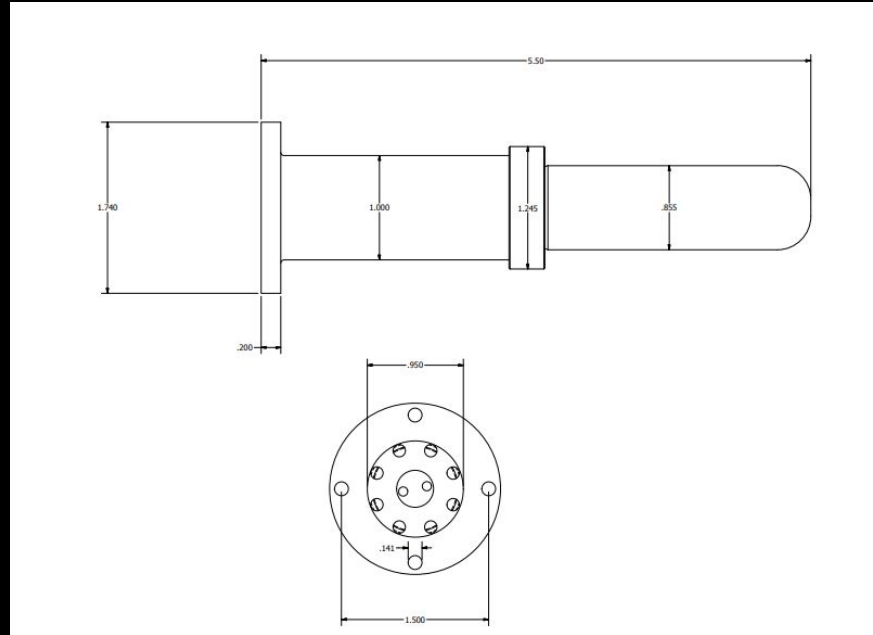

CO₂ Cartridge: Cost Estimate

- Cartridges: \$1.60
- RAPTOR COTS mechanism: \$145
- EAGLE COTS mechanism: \$135
- Solenoid: \$40



CO₂ Cartridge: Pros and Cons

Pros

- Lightweight and compact
- “Tested in vacuum”

Cons

- Unfamiliar system
- Expensive to buy, would take time to replicate correctly
- Need to make parachute bay somewhat airtight
- Potential for pressure-induced deployment

