

RAdminD Business Requirements

Scope of This Document

This document describes a strategy for evaluating the viability of the radmind (“R-Admin-D”) tool for use in managing installation and update of IS&T’s enterprise web applications.

In prior work, ISDA and OIS already selected radmind as the most viable candidate for evaluation against real-world problems, especially for managing configurations of base operating-system packages.

Our strategy uses two enterprise web-application systems as test beds for integration with configuration management: one based in PHP and the other in Java. The business requires certain outcomes from these experiments to demonstrate that this tool will make system integration more efficient. Those business requirements are the focus of this document.

Revision History

09/16/08	Steve Landry	Added proofs of concept and some of the requirements gathered from SAIS
09/18/08	Steve Landry	

Table of Contents

RAdminD Business Requirements.....	1
Business Requirements.....	2
Proof of Concept 1: IS&T Web Site.....	3
Proof of Concept 2: Oracle Application Server (OAS).....	4
Repeatable-Build Library.....	5

Business Requirements

We will use two types of web application-server environments to prove the configuration management concept, PHP and Java. ISDA will use the *IS&T Web Site* systems as the test bed for systems based in PHP. SAIS will use one of their Oracle Application Server (OAS) products (specific product to be determined) as the test bed for Java-based web applications.

We must prove the following outcomes, or benefits to the business, in order to move on to the next step of using radmind as the core of a configuration-management service out of OIS.

- The concept systems will generate reusable artifacts.
 - In this context, “artifacts” are radmind loadsets, or builds.
 - “Reusable” means that artifacts derived from the two concept projects can have an immediate benefit for other existing systems based on similar technology.
- Managed artifacts will have the immediate effect of shortening the runbooks and shortening the time to reproduce an installation of the concept systems.
 - We do not expect the result of this proof to be a push-button installation of any given system.
 - We expect new runbooks that include instructions for layering loadsets and then configuring them to be specific instances.
 - We expect a reduction in time for documentation.
- Managed loadsets must be designed to provide incentive for other project teams to base future projects around the benefits derived from managed configurations.
- Loadsets must be able to be grouped, by some mechanism of either process or technology, into standard template systems. For instance, a stock PHP server or a stock OAS server useful for projects as yet not conceived.
 - Example: PHP system = RHEL5 + Apache/SSL + PHP with standard extension pack.
 - This takes into account that a patch at one level tier affect loadsets installed on top of it.
 - “Groups” must be tested and iterated as a unit.
- Security. Loadsets must be designed in such a way that security patches can be quickly propagated. This is in direct conflict with the requirement above and must be reconciled.
- A manager or project manager should be able to quickly get a report of which loadsets at which versions form the basis for the machine, or set of machines, in question.
 - A versioning scheme must be clearly defined so that their meanings can become part of the local lexicon.
- Demonstrate that the configuration-management solution eases the process of roll out from preproduction to operational support. An application-management team should be able to more easily produce and package systems for deployment to hands-off production environments.

Proof of Concept 1: IS&T Web Site

We will use the IS&T Web Site systems to demonstrate the practical application of radmind. This allows us to prove the concept in real practice but within a contained deliverable. Once proved, other PHP systems can be integrated as required or as time permits.

The IS&T Web Site project has the following useful qualities:

- The Apache/Shibboleth/PHP configuration matches the pattern of other systems so the potential to reuse this pattern is immediate.
- Current installation procedures require us to build our own PHP for each given system. This is more labor intensive than setting up systems with other technologies. Operationally, we gain immediate efficiencies.
- PHP has many dependencies on OS-level libraries. A PHP system allows us to test layered configurations and grouped loadset versions to manage dependencies.
- The configuration-management project team is directly familiar with these systems.
- This particular project is designed to be built by ISDA but rolled out to OIS for production support. Therefore, this is a good test of whether configuration management makes it easier to provide clean operational handoff.

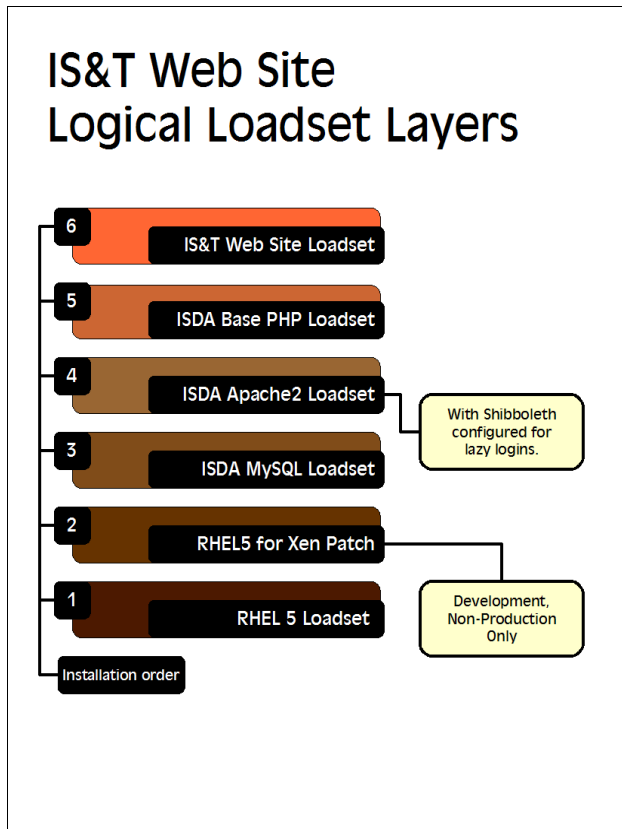

Proof of Concept 2: Oracle Application Server (OAS)

SAIS will choose a specific one of their several products based on OAS to prove the ability to manage the configuration of their enterprise web applications at some level. Until we select that specific product, this section will deal with known consistencies across the OAS environments.

We will use a set of OAS systems to demonstrate the practical application of radmind. This allows us to prove the concept in real practice but within a contained deliverable. Once proved, other OAS systems can be integrated as required or as time permits.

The IS&T Web Site project has the following useful qualities:

- Many SAIS web applications are developed on top of the OAS platform. Reusable artifacts and processes are nearly inevitable.
- If the configuration-management system is successful, a significant shortening of the time to set up OAS instances will occur.
- Unlike other Java web-application servers in our environment, apache-to-servlet engine mapping is standardized and managed through a web console. That makes this example simpler to configuration (we estimate) than other java application-server solutions.
- Configuration-management of OAS might prove simpler than other java web-

application servers, but it will inform processes for other platforms.

