

Device Characterization Project 3 - November 15, 2002

NPN BJT CHARACTERIZATION

Due: November 27, 2002 at lecture

In this project, you will characterize the current-voltage characteristics of an npn bipolar junction transistor (BJT). To do this, you will use the *MIT Microelectronics WebLab*. Refer to the User Manual for instructions on how to use the system.

Two identical npn BJTs are available in weblab. They are labeled "6.720 npn BJT." The terminal connection configuration is identical for both of them and is available on line. This exercise involves three separate phases: (i) measurement and graphing, (ii) model parameter extraction, and (iii) comparison of model with measurements. Take the measurements specified below. When you are happy with the results (as judged by the characteristics displayed through the web), download the data to your local machine for more graphing and further analysis. You will find useful to study the contents of *Appendix A* which describes the ideal model for the I-V characteristics of an npn BJT.

Important note: For all measurements, hold V_{BE} (or V_{BC}) between 0 and 0.9 V, and V_{CE} between 0 and ± 4 V.

Here is your assignment.

1. (10 points) Measure and download the *common-emitter output characteristics* of the BJT. This is a plot of I_C (linear scale) vs. V_{CE} (linear scale) with I_B as parameter for positive V_{CE} . Do this for $0 \leq I_B \leq 100 \mu A$ and $0 \leq V_{CE} \leq 4 V$. In your local machine and using your favorite software tool, graph the output characteristics. Turn in a printout of this graph (**graph 1**).
2. (10 points) Measure and download the *common-emitter transfer characteristics* of the BJT in the forward active regime (also known as *Gummel plot*). This is a semilog plot of I_C and I_B (logarithmic scale) vs. V_{BE} (linear scale). Do this for $V_{CE} = 2.5 V$. In your local machine graph the Gummel plot. Turn in a printout of this graph (**graph 2**). In a separate plot, graph the current gain of the bipolar transistor vs. I_C . This is a semilog plot of $\beta_F = I_C/I_B$ (linear scale) vs. I_C (logarithmic scale). The lower end of the I_C scale should be $I_C = 10^{-7} A$. Turn in a printout of this graph (**graph 3**).

3. (10 points) Measure and download the *reverse common-emitter output characteristics* of the BJT. This is a plot of I_C (linear scale) vs. V_{CE} (linear scale) with I_B as parameter for negative V_{CE} . Do this for $0 \leq I_B \leq 100 \mu A$ and $0 \leq V_{CE} \leq -4 V$. In your local machine graph the reverse output characteristics. Turn in a printout of this graph (**graph 4**).
4. (10 points) Measure and download the *reverse common-emitter transfer characteristics* of the BJT (also known as *reverse Gummel plot*). This is a plot of I_E and I_B (logarithmic scale) vs. V_{BC} (linear scale). Do this for $V_{EC} = 2.5 V$. In your local machine graph the reverse Gummel plot. Turn in a printout of this graph (**graph 5**). In a separate plot, graph the reverse current gain of the bipolar transistor vs. I_E . This is a semilog plot of $\beta_R = I_E/I_B$ (linear scale) vs. I_E (logarithmic scale). Turn in a printout of this graph (**graph 6**).
5. (15 points) From the forward and reverse Gummel plots, extract V_{BEon} and V_{BCon} , respectively. Define these voltages as the values of V_{BE} and V_{BC} that yield $I_B = 10 \mu A$. Derive $V_{CEsat} = V_{BEon} - V_{BCon}$.
6. (15 points) From the forward and reverse Gummel plots, extract the model parameters I_S , β_F and β_R . Refer to Appendix A for the definitions and roles of these parameters.
7. (20 points) Using the model parameter set just derived, play back the characteristics of the BJT and compare them with the measurement data. As model, use equations 1-3 in Appendix A. Construct the following graphs that include both measurements and model calculations. Use individual dots for the data points and continuous lines for model calculations.

graph 7: Common-emitter output characteristics in forward regime. Print this graph.

graph 8: Gummel plot in forward regime. Print this graph.

graph 9: Common-emitter output characteristics in reverse regime. Print this graph.

graph 10: Gummel plot in reverse regime. Print this graph.

8. (5 points) The model can be refined by accounting for the finite output conductance of the device. From the forward output characteristics, extract the Early voltage V_A . Refer to Appendix A for the definition and role of this parameter.
9. (5 points) Replay the common-emitter output characteristics of the device in the forward regime using the model set that incorporates V_A (Equations 4-6 in Appendix A). Turn in this graph (**graph 11**).

Additional information and assorted advice

- This project might take a substantial amount of time. You should start early.

- Weblab supports 8 devices at any one time (not documented in manual). The device under test is selected through the *Device* menu in the *Channel Definition* frame. Use any one of the devices labeled "NPN BJT". The device location might change as weblab is being used in other subjects this semester.
 - The model parameter determination should not demand extensive numerical analysis. There is no need to do regressions or least-squares fits.
 - The required graphs need not be too fancy, just simply correct. They must have proper tickmarks, axis labeling and correct units. If there are several lines, each one should be properly identified (handwriting is OK).
-
- You have to exercise care with these devices. Please do not apply a higher voltage than suggested. The BJTs are real and they can be damaged. If the characteristics look funny, try a different device and let us know.
 - It will be to your advantage to make good use of the *Set-up* management functions that are built into the tool under the *file* menu of the *channel definition* panel (see manual).
 - For research purposes, the system keeps a record of all logins and all scripts that each user executes.

Note on collaboration policy

In carrying out this exercise (as in all exercises in this class), you may collaborate with somebody else that is taking the subject. In fact, collaboration is encouraged. However, this is not a group project to be divided among several participants. Every individual must have carried out the entire exercise, that means, using the web tool, graphing the data off line, and extracting suitable parameters. Everyone of these items contains a substantial educational experience that every individual must be exposed to. If you have questions regarding this policy, please ask the instructor. Prominently shown in your solutions should be the name of the person(s) you have collaborated with in this homework.

Appendix A: BJT I-V characteristics

The conventions for terminal naming, voltage and current notations, and the various regimes of operation for an npn BJT are all shown below:

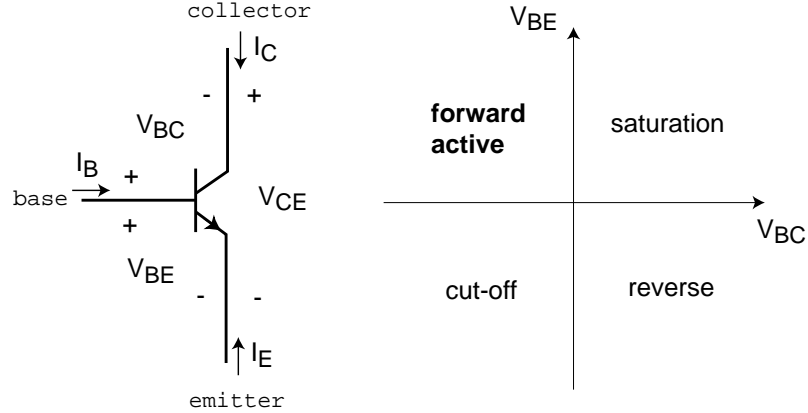

The ideal I-V characteristics of an npn BJT are given by the following set of equations:

$$I_C = I_S \left(\exp \frac{qV_{BE}}{kT} - \exp \frac{qV_{BC}}{kT} \right) - \frac{I_S}{\beta_R} \left(\exp \frac{qV_{BC}}{kT} - 1 \right) \quad (1)$$

$$I_B = \frac{I_S}{\beta_F} \left(\exp \frac{qV_{BE}}{kT} - 1 \right) + \frac{I_S}{\beta_R} \left(\exp \frac{qV_{BC}}{kT} - 1 \right) \quad (2)$$

$$I_E = -\frac{I_S}{\beta_F} \left(\exp \frac{qV_{BE}}{kT} - 1 \right) - I_S \left(\exp \frac{qV_{BE}}{kT} - \exp \frac{qV_{BC}}{kT} \right) \quad (3)$$

In the forward active regime ($V_{BE} > 0$, $V_{BC} < 0$), these equations simplify to:

$$I_C \simeq I_S \exp \frac{qV_{BE}}{kT}$$

$$I_B \simeq \frac{I_S}{\beta_F} \left(\exp \frac{qV_{BE}}{kT} - 1 \right)$$

$$I_E \simeq -I_S \exp \frac{qV_{BE}}{kT} - \frac{I_S}{\beta_F} \left(\exp \frac{qV_{BE}}{kT} - 1 \right)$$

In the reverse regime ($V_{BE} < 0$, $V_{BC} > 0$), the equations simplify to:

$$I_C \simeq -I_S \exp \frac{qV_{BC}}{kT} - \frac{I_S}{\beta_R} \left(\exp \frac{qV_{BC}}{kT} - 1 \right)$$

$$I_B \simeq \frac{I_S}{\beta_R} \left(\exp \frac{qV_{BC}}{kT} - 1 \right)$$

$$I_E \simeq I_S \exp \frac{qV_{BC}}{kT}$$

The common-emitter output characteristics of an ideal npn BJT look as in the figure below:

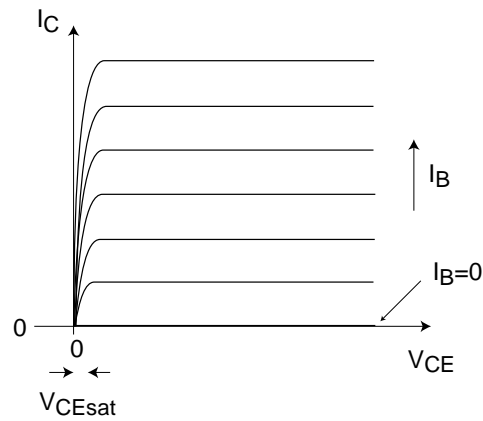

The common-emitter transfer characteristics (*Gummel plot*) of an ideal npn BJT look as in the figure below:

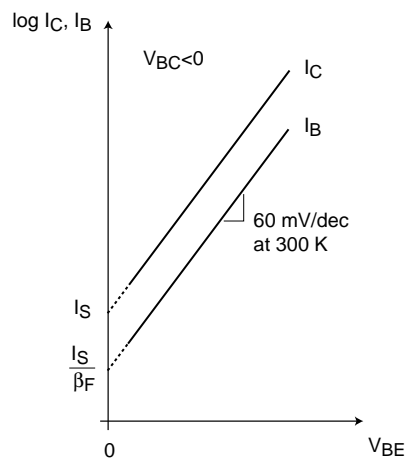

A more refined model includes the finite output conductance of the device (*Early effect*) through a new parameter called the Early voltage, V_A . In the forward active regime, the equation set becomes:

$$I_C \simeq I_S \left(1 - \frac{V_{BC}}{V_A}\right) \exp \frac{qV_{BE}}{kT}$$

$$I_B \simeq \frac{I_S}{\beta_F} \left(\exp \frac{qV_{BE}}{kT} - 1\right)$$

$$I_E \simeq -I_S \left(1 - \frac{V_{BC}}{V_A}\right) \exp \frac{qV_{BE}}{kT} - \frac{I_S}{\beta_F} \left(\exp \frac{qV_{BE}}{kT} - 1\right)$$

One way of estimating the Early voltage is as indicated in the figure below:

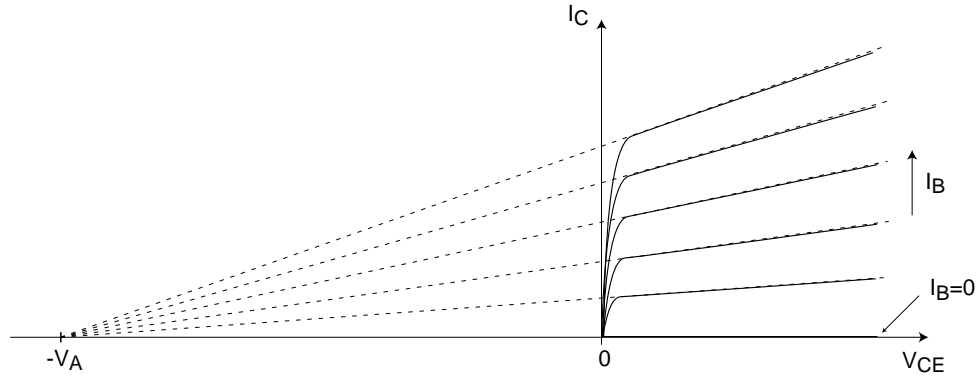

The complete set of equations of the BJT including the Early effect becomes:

$$I_C = I_S \left(1 - \frac{V_{BC}}{V_A}\right) \left(\exp \frac{qV_{BE}}{kT} - \exp \frac{qV_{BC}}{kT}\right) - \frac{I_S}{\beta_R} \left(\exp \frac{qV_{BC}}{kT} - 1\right) \quad (4)$$

$$I_B = \frac{I_S}{\beta_F} \left(\exp \frac{qV_{BE}}{kT} - 1\right) + \frac{I_S}{\beta_R} \left(\exp \frac{qV_{BC}}{kT} - 1\right) \quad (5)$$

$$I_E = -\frac{I_S}{\beta_F} \left(\exp \frac{qV_{BE}}{kT} - 1\right) - I_S \left(1 - \frac{V_{BC}}{V_A}\right) \left(\exp \frac{qV_{BE}}{kT} - \exp \frac{qV_{BC}}{kT}\right) \quad (6)$$