

Massachusetts Institute of Technology
Department of Electrical Engineering and Computer Science

6.002 – Circuits & Electronics
Fall 2007

Problem Set #11

Issued 11/20/2007 – Due 11/30/2007

Introduction

With the exception of Problem 6, this homework assignment focuses on the analysis and design of a system for playing back a digitally-stored audio signal. Additionally, Problems 11.1 through 11.5 of this assignment serve as the pre-lab exercises for Lab #4, which will involve the construction, testing and demonstration of the audio playback system. *Consequently, you should save a copy of your results for use during Lab #4.*

A block diagram of the audio playback system is shown in Figure 1. At the center of the system is a digital memory in which 32,768 samples of the audio signal are stored. Each sample in the memory has a unique numerical address between 0 and 32,767, inclusive. Consecutive samples are stored at consecutive addresses.

To obtain 32,768 consecutive samples of the audio signal, 4.096 seconds of continuous analog audio signal are first sampled at an 8-kHz rate. The analog audio samples are then digitized by an 8-bit analog-to-digital converter. That is, the samples are quantized to take on one of 256 possible discrete digital values between 0 and 255, inclusive. Here, the digital value of 0 corresponds to the most positive audio signal level, and the digital value of 255 corresponds to the most negative audio signal level. The resulting digital data is then written into the memory.

To retrieve the stored audio signal samples in sequence at the proper rate, the memory is addressed by a counter which counts from 0 to 32,767 at an 8-kHz rate established by an external clock. After counting to 32,767 the counter returns to 0, and the retrieval process repeats itself. As the memory address increments, the corresponding data appears at the memory output. This data is converted back to an analog voltage in a piecewise constant manner by a digital-to-analog (D/A) converter.

During the course of recording and playing back the analog audio signal, the signal is sampled

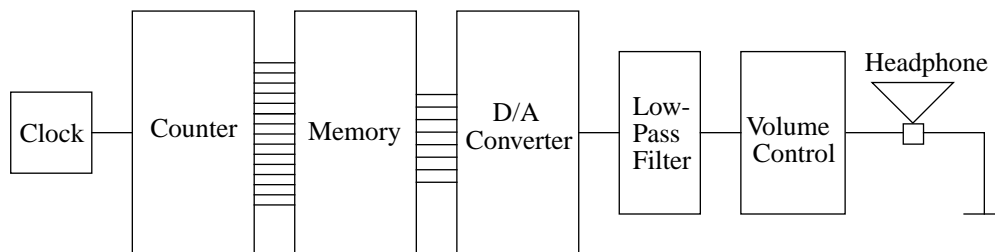

Figure 1: block diagram of the audio playback system.

in time, quantized in amplitude, and reconstructed in a piecewise constant manner. As you will learn in 6.003, this process introduces undesirable high-frequency components into the signal. To minimize the perceived impact of these components, the signal is filtered by a low-pass filter after it is reconstructed by the digital-to-analog converter. Finally, the signal is amplified by a power amplifier which in turn drives a speaker. In Lab #4, you will use a piezo-electric speaker, which does not require much power. In this case, the final power-amplifier stage is not strictly necessary. Nonetheless, the stage is included here, and is used to implement volume control.

In the course of this homework assignment you will analyze and design four of the functional blocks shown in Figure 1. These blocks are the clock, the digital-to-analog converter, the low-pass filter and the power amplifier. In Lab #4, you will construct these blocks and verify that they perform as desired. Then, you will combine them with the counter, the read-only memory and the speaker to construct and demonstrate the entire audio play-back system. Since you will construct the system from the components in your 6.002 lab kit, your design of the blocks must account for the fact that the available components are limited.

Problem 11.1: The Clock

The circuit shown in Figure 2 is the system clock, which is a square-wave oscillator followed by a CMOS inverter; the inverter functions only as a (negative-gain) buffer. The oscillator is constructed from another CMOS inverter, a resistor and a capacitor. Both inverters are powered between the positive supply voltage V_S and ground, and both exhibit the hysteretic input-output characteristic defined in the figure. The inverters are otherwise ideal.

- (A) Assume that v_{CAP} has just charged up to V_H so that v_{OSC} has just switched to 0 V. How much time elapses before v_{CAP} decays to V_L , which in turn causes v_{OSC} to switch to V_S ?
- (B) Assume that v_{CAP} has just decayed to V_L so that that v_{OSC} has just switched to V_S . How much time elapses before v_{CAP} charges up to V_H , which in turn causes v_{OSC} to switch to 0 V?
- (C) Determine the frequency of the oscillator in terms of R , C , V_L , V_H and V_S .
- (D) Assume that $V_L = 1.8$ V, $V_H = 3.0$ V and $V_S = 5.0$ V. Choose values for R and C so that the

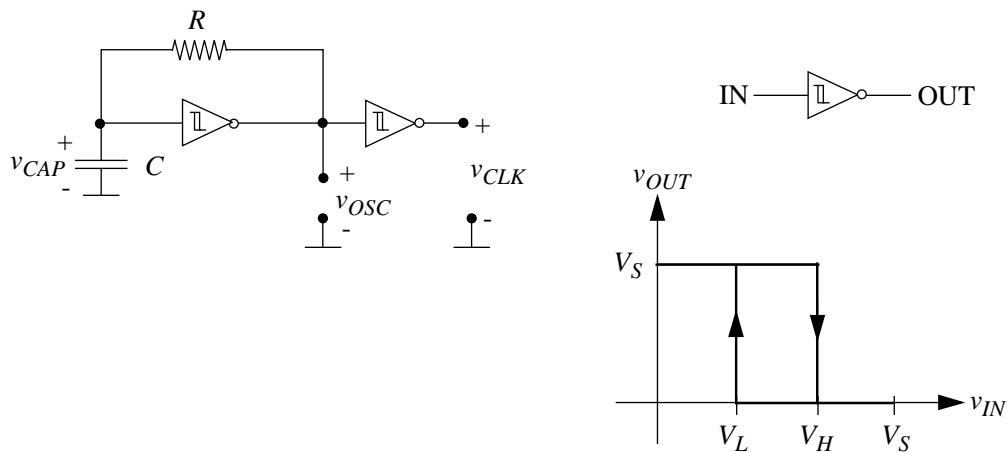

Figure 2: the system clock.

oscillator oscillates at or very near 8-kHz. Since oscillator frequency alone under specifies R and C , there is no single correct choice. Therefore, choose values for R and C that are easily implemented with the components in the 6.002 lab kit.

- (E) For the choice of R and C from Part (D), sketch and clearly label a single graph that displays v_{CAP} , v_{OSC} and v_{CLK} as a function of time over one period of oscillation.

Problem 11.2: The Digital-To-Analog Converter

The circuit shown in Figure 3 is the digital-to-analog converter. The voltage sources v_{DB0} through v_{DB7} represent the voltages supplied by the eight data bits of the digital memory, DB0 through DB7. These voltages will be approximately 5 V when the corresponding data bit is a logical high, and approximately 0 V when the corresponding data bit is a logical low. The voltage v_{OFF} , which is set by a potentiometer, is an offset voltage that is used to center the output of the converter around 0 V. Assume that the op-amp in the converter is ideal.

- (A) Determine v_{DAC} as a function of v_{DB0} through v_{DB7} , and v_{OFF} . Hint: use superposition.
- (B) With $v_{OFF} = 0$ V, the output of the digital-to-analog converter should span the range of 0 V to -2.5 V. Thus, the output of the converter should be given by

$$v_{DAC} = -2.5 \text{ V} \sum_{i=0}^7 \frac{2^i}{255} DBi$$

where each data bit DBi takes on the numerical value of 1 when high and 0 when low. In this manner, each successive data bit from $DB0$ to $DB7$ is given a voltage weighting twice that of the preceding data bit, making it possible for the converter to output voltages from 0 V to -2.5 V in steps of $-2.5/255$ V. Given this, determine R_2 in terms of R_1 .

The voltage rating of the headphone is approximately ± 1.25 V. Since the low-pass filter and buffer between the converter and the speaker both have unity voltage gain over the frequency range of interest, the output range of the analog-to-digital converter must be designed to match the headphone rating. This is why the range is chosen to be 0 V to -2.5 V, with $v_{OFF} = 0$.

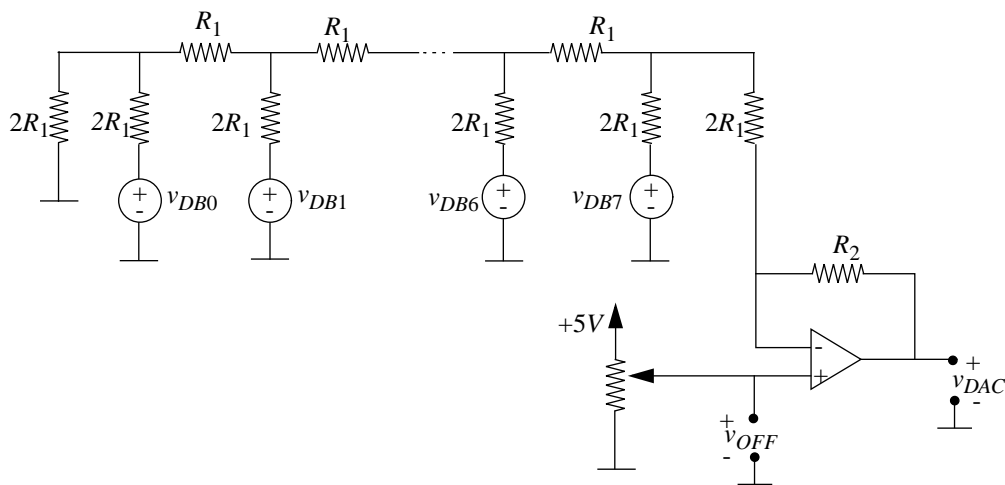

Figure 3: the digital-to-analog converter.

Note further that the output range of the converter is negative. This is because the converter is based upon the inverting amplifier configuration.

- (C) The role of v_{OFF} is to offset the output of the digital-to-analog converter so that it is centered around 0 V. That is, with DB0 through DB7 all low, v_{DAC} should be 1.25 V, and with DB0 through DB7 all high, v_{DAC} should be -1.25 V. Given this, what must be the value of v_{OFF} ?
- (D) Assume that $R_1 = 10 \text{ k}\Omega$. Use the result of Part (B) to determine R_2 .

Problem 11.3: The Low-Pass Filter

The circuit shown in Figure 4 is the low-pass filter. It is a second-order filter, and is driven by the output of the digital-to-analog converter. Its purpose is to remove the high-frequency components of the audio signal that result from the sampling, quantization and reconstruction of that signal. Assume that the op-amp in the filter is ideal.

- (A) Assume that the low-pass filter operates in sinusoidal steady state with $v_{\text{DAC}} = \Re\{\tilde{v}_{\text{DAC}}e^{j\omega t}\}$ and $v_{\text{LPF}} = \Re\{\tilde{v}_{\text{LPF}}e^{j\omega t}\}$ where \tilde{v}_{DAC} and \tilde{v}_{LPF} are complex amplitudes. Find the input-output transfer function $H_{\text{LPF}}(\omega)$ of the filter where $H_{\text{LPF}}(\omega) \equiv \tilde{v}_{\text{LPF}}/\tilde{v}_{\text{DAC}}$.
- (B) Using the results of Part (A), find the magnitude and phase of $H_{\text{LPF}}(\omega)$.
- (C) There is no best design for the low-pass filter to meet the needs of the audio playback system. However, with the appropriate choice of C_1 , C_2 and R , the transfer function of one good design will take the form

$$|H_{\text{LPF}}(\omega)| = \frac{1}{1 + (\omega/\omega_{\text{LPF}})^2}$$

where ω_{LPF} is a specified frequency. For this design, show that the low-frequency and high-frequency asymptotes of $|H_{\text{LPF}}(\omega)|$ intersect at $\omega = \omega_{\text{LPF}}$, and therefore that ω_{LPF} is the frequency that delineates the pass band of the low-pass amplifier.

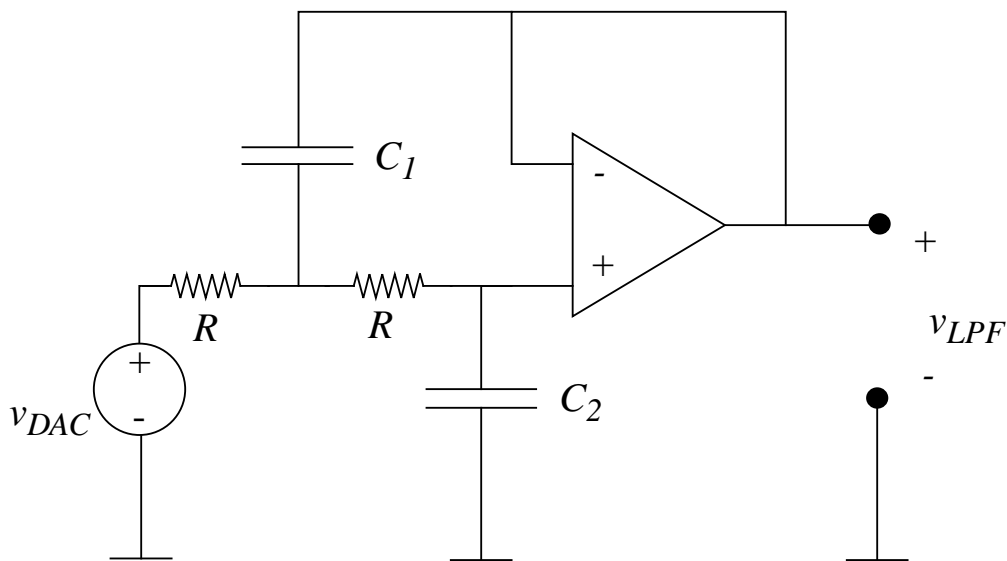

Figure 4: the low-pass filter.

- (D) What constraints must be imposed on C_1 , C_2 and R to obtain the low-pass filter transfer function described in Part (C)?
- (E) Given that the low-pass filter is to be designed as described in Part (C), use the results of Part (D) to choose values for C_1 , C_2 and R so that $\omega_{\text{LPF}} \approx 2\pi \times 4000$ rad/s. Since the results of Part (D) under specify C_1 , C_2 and R , there is no single correct choice. Therefore, choose C_1 , C_2 and R so that they are easily implemented with the components in the 6.002 lab kit.
- (F) Given the choice of C_1 , C_2 and R from Part (E), determine ω_{LPF} , and plot both the log-magnitude and phase of $H_{\text{LPF}}(\omega)$ against log-frequency for $2\pi \times 10^1$ rad/s $\leq \omega \leq 2\pi \times 10^5$ rad/s.

Problem 11.4: The Power Amplifier

Figure 5 shows the output of the low-pass filter driving the power amplifier, which in turn drives the speaker. Ordinarily, the power amplifier would be constructed from a high-power op-amp, or equivalent, because a typical low-power op-amp can not supply the current, and hence the power, required to drive a magnetic speaker. However, this will not be the case in Lab #4, during which the speaker will be a low-power piezo-electric speaker. In this case, a low-power op-amp is adequate.

Because there exists a coupling capacitor at its input, the power amplifier behaves like a high-pass filter. In this way, the amplifier is designed to prevent a possibly damaging DC voltage from being applied to the speaker. This is a particularly serious issue in the case of magnetic speakers, and a less serious issue for the case of piezo-electric speakers. Such a voltage component could be present in v_{LPF} if, for example, v_{OFF} in the analog-to-digital converter is not properly adjusted to balance the output of the converter.

- (A) Assume that the power amplifier operates in sinusoidal steady state with $v_{\text{LPF}} = \Re\{\tilde{v}_{\text{LPF}}e^{j\omega t}\}$ and $v_{\text{OUT}} = \Re\{\tilde{v}_{\text{OUT}}e^{j\omega t}\}$ where \tilde{v}_{LPF} and \tilde{v}_{OUT} are complex amplitudes. Find the input-output transfer function $H_{\text{AMP}}(\omega)$ of the power amplifier where $H_{\text{AMP}}(\omega) \equiv \tilde{v}_{\text{OUT}}/\tilde{v}_{\text{LPF}}$.
- (B) Using the result of Part (A), find the magnitude and phase of $H_{\text{AMP}}(\omega)$.
- (C) Let ω_{AMP} be the frequency at which the low-frequency and high-frequency asymptotes of $|H_{\text{AMP}}(\omega)|$ intersect. Determine ω_{AMP} in terms of R_1 , R_2 and C .

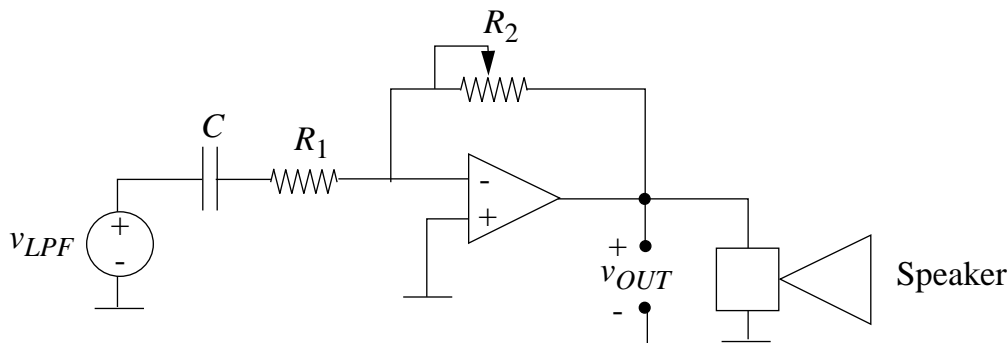

Figure 5: the power amplifier.

- (D) Choose values for R_1 , R_2 and C so that $\omega_{AMP} \leq 2\pi \times 100$ Hz, and $|H_{AMP}(\omega)| = 10$ for $\omega \gg \omega_{AMP}$. Since these conditions alone under specify R_1 , R_2 and C , there is no single correct choice. Therefore, choose values for R_1 , R_2 and C that are easily implemented with the components in the 6.002 lab kit.
- (E) If the original analog signal is recorded with a reduced amplitude, then the power amplifier must compensate by providing more than a 10-fold gain. To provide this gain, R_2 is implemented with a fixed resistor in series with a potentiometer. Design such a modification that provides a variable gain of 10 to 20. Note that the 6.002 lab kit has a limited number of potentiometers.

Problem 11.5: Connecting The Blocks

In the complete audio playback system the output of the digital-to-analog converter is connected directly to the input of the low-pass filter, and the output of the low-pass filter is connected directly to the input of the power amplifier, as shown in Figure 1. Thus, the filter loads the converter, and the amplifier loads the filter. Explain why this loading could be ignored in Problems 2, 3 and 4. That is, explain why the converter, filter and amplifier may each be analyzed and designed in isolation.

Problem 11.6: A WebLab Problem Not Related To Lab #4

This problem studies the differentiator shown below using the ELVIS Lab Client under iLab. This lab client captures transient responses. To run this client go to <iLab.mit.edu> and log in, select the ELVIS Lab Client, and then launch the lab.

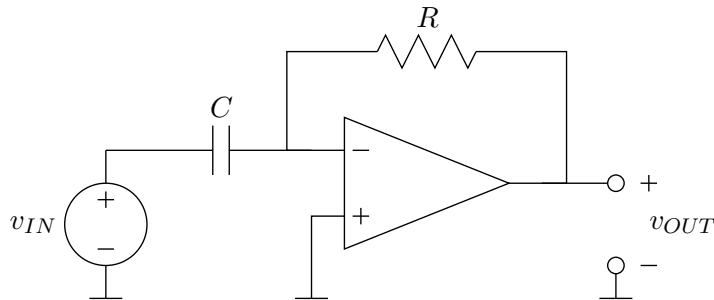

- (A) Analytically determine v_{OUT} as a function of v_{IN} for the differentiator shown above. Assume that the op-amp is ideal.
- (B) Use the ELVIS Lab Client to measure the input-output behavior of the experimental differentiator given a triangle wave at its input, and provide a screen shot of this behavior. To do so, select the signal generator (FGEN) and set its parameters to: WaveForm = TRIANGULAR; Frequency = 1 kHz; Amplitude = 1 V; and Offset = 0 V. Second, select the output measurement unit (SCOPE) and set its parameters to: Sampling Rate = 100 kHz; and Duration = 1 ms. Third, run the experiment. Finally, select v_{IN} for the Y1 axis and v_{OUT} for the Y2 axis, and capture a screen shot. Use linear axes everywhere.
- (C) From the input-output behavior measured in Part (B), determine the RC time constant in the experimental differentiator.

- (D) Suppose that v_{IN} is a voltage step from -1 V to $+1$ V at $t = 0$. Analytically determine v_{OUT} in the differentiator shown above.
- (E) Use the ELVIS Lab Client to measure the input-output behavior of the experimental differentiator given a square wave at its input, and provide a screen shot of this behavior. To do so, select the signal generator (FGEN) and change its waveform parameter to WaveForm = SQUARE. Finally, run the experiment and capture a screen shot.
- (F) From the screen shot measured in Part (E), estimate the area under the “impulse” that results at v_{OUT} from a step at v_{IN} . This may be done either numerically or graphically. Does the area agree with your determination of the RC time constant in Part (C)?