

Homework #2 - February 11, 2009

Due: February 18, 2009 at recitation

No late homework accepted

1. [6 Point]: In each circuit shown below, three light bulbs are driven by a single source. In two of the circuits the source is a voltage source, and in the other it is a current source. Assume that one of the three light bulbs burns out and becomes an open circuit. Do the other two light bulbs get brighter, get dimmer, or exhibit no change in intensity? Why?

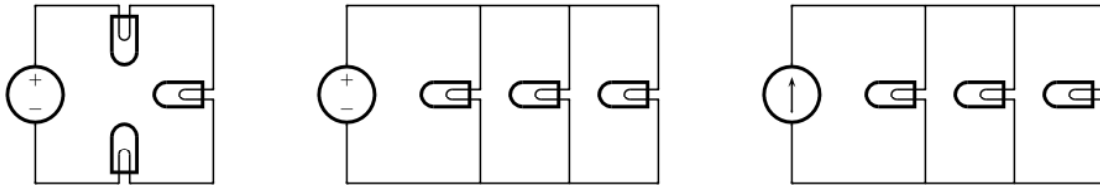

2. [14 Point]: Employing the node method, develop a set of simultaneous equations for the 6-resistor network shown below that can be used to solve for the three unknown node voltages e_1 , e_2 and e_3 . Express these equations in the matrix format:

$$G \begin{bmatrix} e_1 \\ e_2 \\ e_3 \end{bmatrix} = S$$

where G is a 3×3 matrix of conductance terms and S is a 3×1 vector of terms involving the sources. You **need not** solve the set of equations for the node voltages.

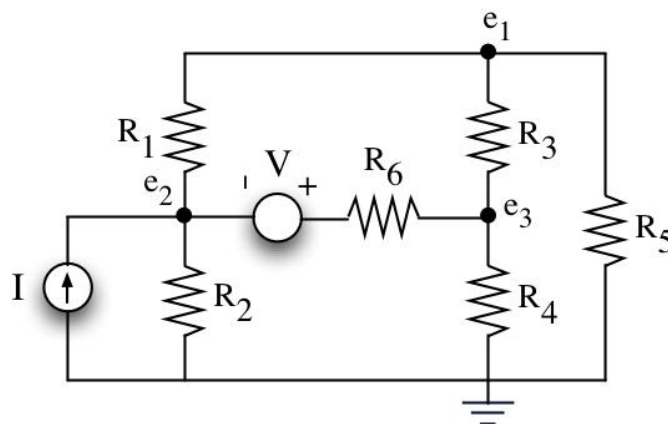

3. [24 Points]: Parts (A) through (C) of this problem analyze the network shown below by two methods: superposition and the direct application of the node method. You should compare for yourself the work required to analyze the network by these two methods. For Parts (A) through (C), assume that the port terminals to the right are left open.

(A) [6 Points]: First, use superposition to determine e_1 and e_2 . That is, superpose the two partial node voltages obtained with only single sources active to find the total node voltages. Remember that a zero-valued voltage source is a short circuit, and a zero-valued current source is an open circuit. Hint: rather than employing the node method twice, once for each partial analysis, consider employing alternative simpler analyses involving the use of parallel and series resistor combinations, and voltage and current dividers.

(B) [6 Points]: Second, use the node method to directly determine e_1 and e_2 in total.

(C) [4 Points]: Compare the solutions to Parts (A) and (B). The two solutions should be the same.

(D) [8 Points]: Determine the Thevenin and Norton equivalents of the circuit as viewed from the port adjacent to R_4 .

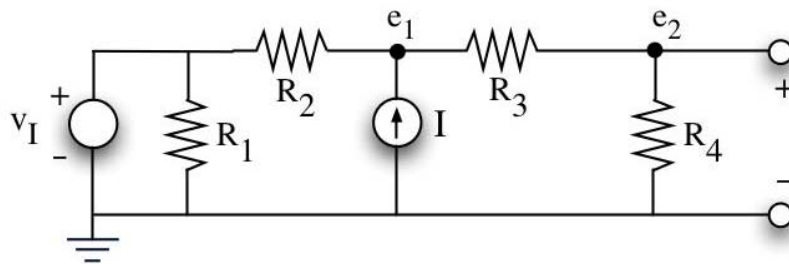

4. [26 Points]: Two networks, N_1 and N_2 , are described graphically in terms of their i - v relations, and connected together through two resistors, as shown below.

(A) [16 Points]: Find the Thevenin and Norton equivalent circuits of N_1 and N_2 .

(B) [10 Points]: Find the currents i_1 and i_2 that result from the interconnection of N_1 and N_2 in the manner indicated below.

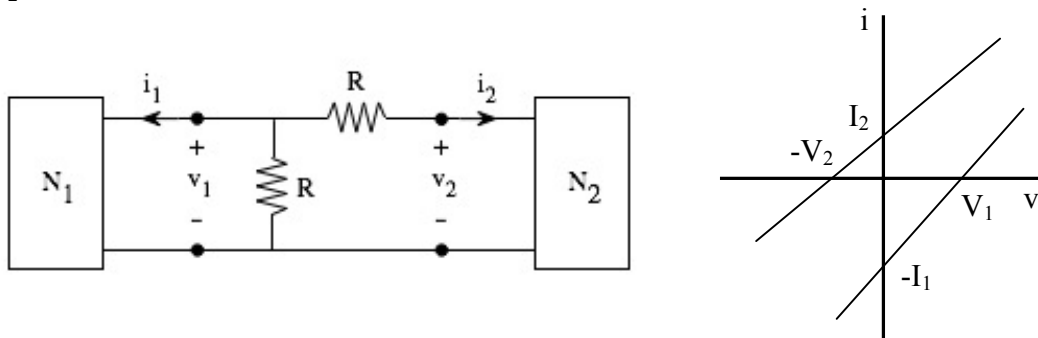

5. [30 Points]: This problem makes use of the iLab Microelectronics Device Characterization Laboratory to measure the voltage-current characteristic of a real diode.

As in Problem 1.4, login to the iLab web site, select the Microelectronics Device Characterization Lab Client V7.0 and launch it. Then select 6.002 pn diode under the Device menu. This is the device that you will characterize.

To measure the voltage-current characteristic of the diode, you should connect the n-side of the diode (the side with the vertical bar in the symbol) to ground, and drive the p-side (the side with the arrow in the diode symbol) with a voltage source. Refer to the instructions given in Problem 1.4 for programming the SMUs appropriately. Sweep the voltage of the diode between -1 V and 1 V with a 10 mV step. Set the current compliance to 10 mA. Run the experiment and download the data; again see Problem 1.4 for instructions. Make a note of the temperature of the diode which is given in degrees Kelvin at the top center of the Results canvas.

Use your measured voltage and current data for the diode to answer the following questions. As you analyze the data, remember that SMU #1 was set up to limit the diode current to 10 mA, even if the applied voltage attempts to drive a larger current.

(A) [10 Points]: The ideal voltage-current characteristic of the pn diode is given by

$$i_D = I_S \left(\exp \frac{qV_D}{kT} - 1 \right)$$

where $k = 1.38 \times 10^{-23}$ J/K is Boltzmann's constant, T is the diode temperature in degrees Kelvin, and $q = 1.60 \times 10^{-19}$ C is the electron charge. kT/q has a unit of volts, and receives the name of thermal voltage.

Given the measured diode temperature, determine the thermal voltage kT/q .

(B) [10 Points]: Over what range of voltage does the measured diode data exhibit $i_D \approx -I_S$? Is this as expected from the theoretical relation given above?

(C) [10 Points]: Over what range of voltage does the measured diode data exhibit the exponential relation $i_D \approx I_S \exp(qV_D/kT)$? Is this as expected from the theoretical relation given above? Using this exponential branch of the measured data, estimate I_S .

The following hints may help in answering Parts (B) and (C) above.

- Parts (B) and (C) can be answered either graphically or numerically. If you choose a graphical method, then you should plot the downloaded data using MatLab, Excel or another program, or print a screen-shot of the graph produced by the lab. Capturing screen-shots is a platform specific activity; consult the lab documentation for Windows- and Athena-specific advice. If you choose a numerical method, then you could process the downloaded data using MatLab, Excel or another program.
- Before answering Parts (B) and (C), you may find it instructive to examine the measured data visually using the client. In this case, a logarithmic y-axis display is probably best used for Parts (B) and (C).