

Central[™] Semiconductor Corp.

145 Adams Ave., Hauppauge, NY 11788 USA
Phone (631) 435-1110 FAX (631) 435-1824
Manufacturer of World Class Discrete Semiconductors
www.centralsemi.com

BD135
BD137
BD139

NPN SILICON TRANSISTORS

JEDEC TO-126 CASE

DESCRIPTION: The Central Semiconductor BD135, BD137, and BD139 types are NPN Silicon Epitaxial Planar Transistors designed for audio amplifier and switching applications.

MAXIMUM RATINGS: ($T_C=25^\circ\text{C}$ unless otherwise noted)

	<u>SYMBOL</u>	<u>BD135</u>	<u>BD137</u>	<u>BD139</u>	<u>UNIT</u>
Collector-Base Voltage	V_{CB0}	45	60	100	V
Collector-Emitter Voltage	V_{CEO}	45	60	80	V
Emitter-Base Voltage	V_{EBO}		5.0		V
Collector Current	I_C		1.5		A
Peak Collector Current	I_{CM}		2.0		A
Base Current	I_B		0.5		A
Peak Base Current	I_{BM}		1.0		A
Power Dissipation ($T_{mb}\leq 70^\circ\text{C}$)	P_D		8.0		W
Power Dissipation ($T_A=25^\circ\text{C}$)	P_D		1.25		W
Operating and Storage Junction Temperature	T_J, T_{stg}		-65 to +150		$^\circ\text{C}$
Thermal Resistance	Θ_{J-mb}		10		$^\circ\text{C/W}$
Thermal Resistance	Θ_{J-A}		100		$^\circ\text{C/W}$

ELECTRICAL CHARACTERISTICS ($T_C=25^\circ\text{C}$ unless otherwise noted)

<u>SYMBOL</u>	<u>TEST CONDITIONS</u>	<u>BD135</u>		<u>BD137</u>		<u>BD139</u>		<u>UNIT</u>
		<u>MIN</u>	<u>MAX</u>	<u>MIN</u>	<u>MAX</u>	<u>MIN</u>	<u>MAX</u>	
I_{CBO}	$V_{CB}=30\text{V}$		100		100		100	nA
I_{CBO}	$V_{CB}=30\text{V}, T_C=125^\circ\text{C}$		10		10		10	μA
I_{EBO}	$V_{EB}=5.0\text{V}$		100		100		100	nA
BV_{CEO}	$I_C=30\text{mA}$	45		60		80		V
$V_{CE(SAT)}$	$I_C=500\text{mA}, I_B=50\text{mA}$		0.5		0.5		0.5	V
$V_{BE(ON)}$	$V_{CE}=2.0\text{V}, I_C=500\text{mA}$		1.0		1.0		1.0	V
h_{FE}	$V_{CE}=2.0\text{V}, I_C=5.0\text{mA}$	40		40		40		
h_{FE}	$V_{CE}=2.0\text{V}, I_C=150\text{mA}$	63	250	63	250	63	250	
h_{FE}	$V_{CE}=2.0\text{V}, I_C=500\text{mA}$	25		25		25		
f_T	$V_{CE}=5.0\text{V}, I_C=50\text{mA}, f=100\text{MHz}$	190 TYP		190 TYP		190 TYP		MHz

<u>SYMBOL</u>	<u>TEST CONDITIONS</u>	<u>BD135-10</u>		<u>BD135-16</u>	
		<u>MIN</u>	<u>MAX</u>	<u>MIN</u>	<u>MAX</u>
h_{FE}	$V_{CE}=2.0\text{V}, I_C=150\text{mA}$	63	160	100	250

(SEE REVERSE SIDE)

JEDEC TO-126 CASE - MECHANICAL OUTLINE

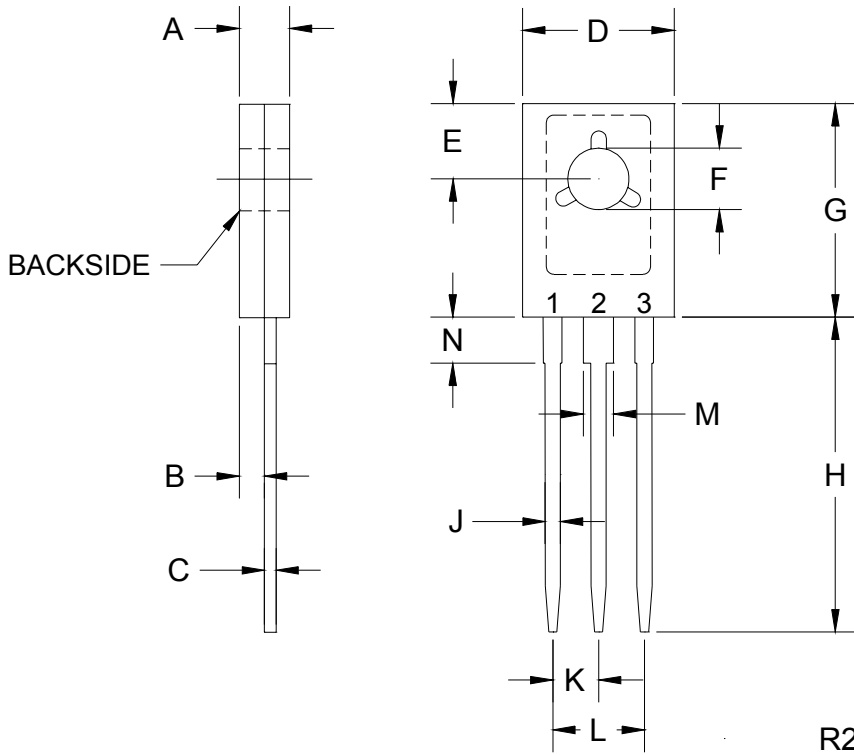

SYMBOL	INCHES		MILLIMETERS	
	MIN	MAX	MIN	MAX
A	0.094	0.106	2.40	2.70
B	0.050		1.27	
C	0.015	0.030	0.38	0.75
D	0.291	0.307	7.40	7.80
E	0.148		3.75	
F	0.118	0.126	3.00	3.20
G	0.413	0.435	10.50	11.05
H	0.618		15.70	
J	0.025	0.035	0.64	0.90
K	0.089		2.25	
L	0.177		4.50	
M	0.045	0.055	1.14	1.39
N	0.083		2.10	

TO-126 (REV:R2)

Lead Code:

1. Emitter
2. Collector
3. Base

Mounting Pad is Common to Pin 2

Central™
Semiconductor Corp.

145 Adams Ave., Hauppauge, NY 11788 USA
Phone (631) 435-1110 FAX (631) 435-1824

Manufacturers of World Class Discrete Semiconductors
www.centrasemi.com